

Gæðaskjal (GSK) GSK-1060  
Date of issue: 22.5.2015 Revision no.:3.0  
Responsible: Einar Friðgeir Björnsson  
Editor: Örvar Ármannsson



*06-Electrical*  
*Low Voltage Standard Technical*  
*Specification (LVSTS)*

---

Doc. no.: NA-06-STS001

**This standard technical specification is subject to change without prior notice. The most current issue will at all times be located on the Nordural web site, [www.nordural.is](http://www.nordural.is).**

## CONTENTS

<b>1</b>	<b>Responsibility</b> .....	<b>6</b>
<b>2</b>	<b>Scope and field of application</b> .....	<b>6</b>
2.1	Scope Definition .....	6
2.2	Document Conflicts.....	6
<b>3</b>	<b>References and abbreviations</b> .....	<b>6</b>
3.1	References .....	6
3.2	Abbreviations .....	6
<b>4</b>	<b>General electrical standard</b> .....	<b>7</b>
4.1	<b>Electrical engineering design</b> .....	<b>7</b>
4.1.1	General .....	7
4.1.2	Voltage levels.....	7
4.1.3	Short circuit calculations.....	8
4.1.4	Arc fault protection.....	8
4.1.5	Engineering and Drawings.....	8
4.1.6	Identification .....	8
4.2	<b>Electrical equipment</b> .....	<b>8</b>
4.2.1	General .....	8
4.2.2	Storage and Protection of Equipment .....	8
4.2.1	Handbooks and documentation .....	8
4.3	<b>General installation and service electricity</b> .....	<b>8</b>
4.3.1	General .....	8
4.3.2	Authorization for electrical works and responsibility for operation .....	9
4.4	<b>Inspections and commissioning</b> .....	<b>9</b>
4.4.1	Inspection.....	9
4.4.2	Commissioning.....	9
4.4.3	Energizing .....	9
4.4.4	Handover.....	9
<b>5</b>	<b>Potroom area – Special Requirements</b> .....	<b>9</b>
5.1	<b>General</b> .....	<b>9</b>
5.1.1	Earth free zone.....	9
5.1.2	Cable routing.....	11
5.1.3	Power distribution system.....	11
5.1.4	Socket outlets within the Earth Free Zone .....	11
<b>6</b>	<b>Earthing</b> .....	<b>11</b>
6.1	<b>Potroom Earth Free Zone</b> .....	<b>11</b>
6.2	<b>General requirements</b> .....	<b>11</b>
6.3	<b>Above ground earth system</b> .....	<b>12</b>
6.4	<b>Equipotential bonding</b> .....	<b>12</b>
6.4.1	Equipotential Bonding of cable installations systems .....	12
6.5	<b>Exclusions</b> .....	<b>12</b>
6.6	<b>EMC requirements</b> .....	<b>13</b>
6.6.1	EMC Earthing of control- and signal cables .....	13
<b>7</b>	<b>Cable installation systems</b> .....	<b>13</b>
7.1	<b>General</b> .....	<b>13</b>

<b>7.2 Compliance standars .....</b>	<b>13</b>
7.2.1 Cable ladders and trays.....	13
7.2.2 Conduits .....	14
<b>8 Cables.....</b>	<b>16</b>
<b>8.1 General requirements .....</b>	<b>16</b>
8.1.1 General .....	16
8.1.2 Cable requirments .....	16
8.1.3 Screen.....	16
8.1.4 Mechanical protection and segregation of cables .....	17
8.1.5 Cable marking .....	17
<b>8.2 400 V ac cables.....</b>	<b>17</b>
<b>8.3 Direct current cables.....</b>	<b>18</b>
<b>8.4 Control- and signal cables.....</b>	<b>19</b>
<b>8.5 Fire detection and alarm cables .....</b>	<b>20</b>
8.5.1 General .....	20
<b>8.6 Ethernet twisted pair cables .....</b>	<b>21</b>
8.6.1 General .....	21
8.6.2 Cat5-e UTP .....	21
<b>8.7 Fibre Optic Cables.....</b>	<b>21</b>
8.7.1 General .....	21
8.7.2 Multi Mode Fibre.....	22
8.7.3 Single mode Fibre .....	23
<b>8.8 Power cables .....</b>	<b>23</b>
8.8.1 Short Circuit Capacity.....	24
8.8.2 Continuous current carrying capacity.....	24
8.8.3 Voltage drop.....	24
<b>8.9 Installation of cables .....</b>	<b>24</b>
8.9.1 General .....	24
8.9.2 Fire precautions.....	25
8.9.3 Segregation.....	25
8.9.4 Cables laid on cable ladders and trays .....	26
8.9.5 Cables laid in conduits.....	26
8.9.6 Cables laid directly in ground.....	26
8.9.7 Cable termination .....	28
<b>9 Panels.....</b>	<b>29</b>
<b>9.1 Panel classifications .....</b>	<b>29</b>
9.1.1 MDB – Main Distribution Boards.....	30
9.1.2 MCC – Motor Control Centers .....	30
9.1.3 DB – Distribution Boards .....	30
9.1.4 Panel construction.....	30
9.1.5 Internal protection.....	31
9.1.6 Internal seperation.....	31
9.1.7 Panel finish.....	32
9.1.8 Panel and equipment labeling .....	32
9.1.9 Panel arc fault protection.....	33
<b>9.2 Panel Accessories.....</b>	<b>33</b>
<b>9.3 Abnormalities .....</b>	<b>33</b>
<b>9.4 Nameplates .....</b>	<b>33</b>
<b>9.5 Earthing and bonding of panels.....</b>	<b>34</b>

<b>9.6</b>	<b>Busbars</b>	<b>34</b>
<b>9.7</b>	<b>Cable entries</b>	<b>34</b>
9.7.1	Cable glands	34
<b>10</b>	<b>Equipment and wiring in panels</b>	<b>35</b>
<b>10.1</b>	<b>Circuit breaker and switch classification</b>	<b>35</b>
10.1.1	ACB – Air Circuit Breaker	35
10.1.2	MCCB – Moulded Case Circuit Breaker	35
10.1.3	MCB – Miniature Circuit Breaker	35
10.1.4	MPCB – Motor protection Circuit Breaker	35
10.1.5	CFS – Combination Fuse Switch	35
10.1.6	LSD – Load Switch Disconnecter	35
10.1.7	On-load fuse switch	36
10.1.8	Load break switches	36
10.1.9	Variable speed drives and soft starters	36
<b>10.2</b>	<b>Control circuit devices</b>	<b>36</b>
<b>10.3</b>	<b>Panel instruments</b>	<b>36</b>
<b>10.4</b>	<b>Circuit breakers</b>	<b>36</b>
10.4.1	General	36
10.4.2	Incoming panel feeder	37
10.4.3	Residual Current Protective Devices	37
10.4.4	Lock out-Tag out	37
<b>10.5</b>	<b>Motor starting</b>	<b>38</b>
<b>10.6</b>	<b>Contactors and relays</b>	<b>38</b>
<b>10.7</b>	<b>Current transformers</b>	<b>38</b>
<b>10.8</b>	<b>Wire terminals</b>	<b>38</b>
<b>10.9</b>	<b>Wiring</b>	<b>38</b>
<b>10.10</b>	<b>Wire marking</b>	<b>39</b>
<b>10.11</b>	<b>Marking and labeling of equipment</b>	<b>39</b>
<b>11</b>	<b>Lighting</b>	<b>40</b>
<b>11.1</b>	<b>General</b>	<b>40</b>
<b>11.2</b>	<b>Design Requirements</b>	<b>40</b>
<b>11.3</b>	<b>Products</b>	<b>40</b>
11.3.1	Indoor lights	40
11.3.2	Emergency and exit lights	41
11.3.3	Outdoor lighting	41
11.3.4	Light poles	41
<b>12</b>	<b>Accessories</b>	<b>41</b>
<b>12.1</b>	<b>General</b>	<b>41</b>
12.1.1	Mounting heights	41
<b>12.2</b>	<b>Junction boxes</b>	<b>41</b>
<b>12.3</b>	<b>Socket Outlets</b>	<b>41</b>
<b>12.4</b>	<b>Light switches</b>	<b>42</b>
12.4.1	General	42
12.4.2	Photoelectric switches	42
12.4.3	Astronomical clock	42
<b>12.5</b>	<b>Heating equipment</b>	<b>42</b>

---

12.5.1	Panel heaters .....	42
12.5.2	Electrical heating fans.....	42
<b>12.6</b>	<b>Network / Data outlets .....</b>	<b>42</b>
<b>12.7</b>	<b>Fire detection and protection.....</b>	<b>42</b>

## 1 RESPONSIBILITY

This Standard Technical Specification (STS) is of responsibility of the owner. The revision and date of issue are on the front page.

All deviations from the specifications must be approved in writing by the Owner.

## 2 SCOPE AND FIELD OF APPLICATION

### 2.1 SCOPE DEFINITION

This Standard Technical Specification details the minimum technical requirements including but not limited to, the design, material quality and workmanship, installation, testing, inspection and identification for electrical installation and service electricity. The provision of this Low Voltage Standard Technical Specification (LVSTS) applies in general as supplementary requirements for the production areas of Norðurál's aluminum smelter.

### 2.2 DOCUMENT CONFLICTS

Any conflicts between the referenced documents shall be identified to the Owner in writing for resolution.

## 3 REFERENCES AND ABBREVIATIONS

### 3.1 REFERENCES

All equipment, materials, workmanship, design calculation and tests shall be performed in compliance and read in conjunction with the NA-00-STS001 General Technical Standard and other relevant standards.

The relevance order of standards shall be according to NA-00-STS001.

All materials intended for use at NA shall be approved by the Owner.

### 3.2 ABBREVIATIONS

- ACB Air Circuit Breaker
- AKS Aluminum Kennzeichen System
- AC Alternating Current
- CENELEC Comité Européen de Normalisation ELEctrotechnique  
European Committee for Electrotechnical Standardization
- CT Current Transformer
- CFS Combination fuse-switch unit
- DC Direct Current
- DB Distribution Board
- EMC Electromagnetic compatibility
- HDPE Insulator material: High density polyethylene – PEX insulation
- IEC International Electrotechnical Commission
- IP Ingress Protection
- IT Earthing configuration of an electrical distribution network

- ÍST Prefix for Icelandic Standards
- LMÍ Landmælingar Íslands (National Land Survey of Iceland)
- LSD Load Switch Disconnecter
- LSZH Low Smoke Zero Halogen
- LV Low Voltage
- LVSTS Low Voltage Standard Technical Specification
- MVS Mannvirkjastofnun (Iceland Construction Authority)
- MCB Miniature Circuit Breaker
- MCC Motor Control Cubicle
- MCCB Molded Case Circuit Breaker
- MDB Main Distribution Board
- MPCB Motor Protection Circuit Breaker
- NA Norðurál ehf / Norðurál Grundartangi ehf / Norðurál Helguvík ehf
- OTDR Optical Time Domain Reflectometer
- PE Protective earth
- PVC Insulating material: Polyvinyl chloride
- PWM Pulse Width Modulation
- SAM Prefix for Icelandic Standard's Harmonic Documents
- TN-C-S Earthing configuration at Nordural's electrical distribution network
- XLPE Insulating material: Cross-linked polyethylene
- VSD Variable Speed Drive

## 4 GENERAL ELECTRICAL STANDARD

### 4.1 ELECTRICAL ENGINEERING DESIGN

#### 4.1.1 GENERAL

All requirements of electrical installations and equipment shall be in accordance with NA-00-STS001 General Standard Technical Specification, local regulation no. 678/2009 IS: *Reglugerð um raforkuvirki*, ÍST 200:2006 *Electrical installations of buildings*, this Low Voltage Standard Technical Specification (LVSTS) and relevant CENELEC (EN documents) or IEC standards. ÍST 200:2006 *Electrical Installations of buildings* is in general in conformance with the CENELEC document HD 384.

#### 4.1.2 VOLTAGE LEVELS

The following are the stipulation for the power- and control voltages, at NA

Alternating Current (AC) voltage:

3-phase, 50 Hz, 400/230 V AC, 5 wire TN-C-S system according to ÍST 200,

Direct Current (DC) voltages for control systems:

- a. 110 V DC, ( $\pm 15\%$ ) unearthed 2 wire IT system according to ÍST 200.
- b. 48 V DC, ( $\pm 15\%$ ) unearthed 2 wire IT system according to ÍST 200
- c. 24 V DC, ( $\pm 15\%$ ) unearthed 2 wire IT system according to ÍST 200.

#### **4.1.3 SHORT CIRCUIT CALCULATIONS**

The Owner will supply the designer with necessary short circuit power information at the termination point.

The designer shall supply short circuit calculations for the installation. These calculations are subject for the approval of the Owner. The designer shall supply the Owner with necessary information about cables, circuit breakers, form of MDB's etc. so that the Owner can take this into the calculation of short circuit in all the plant.

#### **4.1.4 ARC FAULT PROTECTION**

The Owner has classified the arc fault intensity for all MDB's. The Work provider shall take necessary precautions and use protective equipment and act according to NA safety procedure when working with live Low voltage boards.

#### **4.1.5 ENGINEERING AND DRAWINGS**

All engineering design drawings shall be in accordance with the NA-00-STSXXX (Unpublished STS).

#### **4.1.6 IDENTIFICATION**

All equipment, including equipment within panels, and cables shall be neatly and clearly marked as indicated on the schematic and wiring diagrams.

The designer shall in his documentation use the AKS-Identification system as described in NA-00-STS001 General Standard Technical Specification.

### **4.2 ELECTRICAL EQUIPMENT**

#### **4.2.1 GENERAL**

All equipment and materials shall be in accordance with the NA-00-STS001 General standard technical specification and other relevant standards.

Whenever no special mention of temperature rise is made, it shall be understood that the temperature rise is in accordance with the CENELEC or IEC recommendations.

#### **4.2.2 STORAGE AND PROTECTION OF EQUIPMENT**

All equipment shall be stored and protected as described in the NA-00-STS001 General standard technical specification.

#### **4.2.1 HANDBOOKS AND DOCUMENTATION**

Handbooks and documentation of electrical equipment and materials shall be delivered to the Owner as described in NA-00-STSXXX (Unpublished STS).

### **4.3 GENERAL INSTALLATION AND SERVICE ELECTRICITY**

#### **4.3.1 GENERAL**

This Specification defines the general standards of workmanship, material requirements and construction methods that are required in the execution of the electrical installation works.



### **4.3.2 AUTHORIZATION FOR ELECTRICAL WORKS AND RESPONSIBILITY FOR OPERATION**

According to Icelandic regulations, an authorized electrical contractor shall be responsible for all electrical works needed for the installation. He is responsible for the electrical safety of the installed equipment until it has been formally handed over to the Owner.

## **4.4 INSPECTIONS AND COMMISSIONING**

### **4.4.1 INSPECTION**

Before the equipment is formally handed over to the Owner, the authorized electrical contractor shall fully inspect all electrical installations according to inspection procedure (forms and inspection rules IS: Skoðunarreglur) as prescribed by MVS.

### **4.4.2 COMMISSIONING**

The Work provider shall demonstrate the functionality of the equipment and verify that equipment is in accordance with the design specifications.

### **4.4.3 ENERGIZING**

Prior to energizing any MDB's or other installations the Work provider shall obtain formal approval from the Owner.

### **4.4.4 HANDOVER**

When installation is completed then the installed equipment shall be formally handed over to the owner.

## **5 POTROOM AREA – SPECIAL REQUIREMENTS**

### **5.1 GENERAL**

The Potroom area is defined as an Earth Free Zone with exceptions as shown on figure 1 and figure 2. All electrical design shall be based on this definition.

#### **5.1.1 EARTH FREE ZONE**

The aluminum reduction process requires very high DC currents to flow through each pot cell. This DC current flows through uninsulated conductors from one pot cell to another. The pot cells are located in buildings called Potrooms.

The current carrying system is isolated from earth and therefore it is defined as floating DC system. It is of the highest priority to prevent short-circuit between this floating system and earth. To prevent electrification of personnel there is created an Earth Free Zone around each pot.

NA has issued a security pamphlet illustrating cautionary working procedures and other safety issues. Everyone working in the Potrooms is encouraged to familiarize themselves with the pamphlet's content.

It is forbidden to use earthed equipment inside the Earth Free Zone and therefore earthed extension cords are forbidden within these zones. Electrical equipment inside the Earth Free Zone shall be powered from isolating transformers with a secondary voltage of max. 400 V and without earthing of the secondary circuit.

All cable ladders, cable installations systems, ducts etc. (conducting materials) inside the Earth Free Zone need to be isolated from earth. Therefore, a segregation is needed when such equipment is extended into the Earth Free Zone. The extension (length) of the separation has to be such that a person can't touch both ends of the conducting material at the same time. If necessary the conduction material can be separated in two places to minimize the possibility of coupling over the separation of the conducting material by touching.

The PE-conductor (green/yellow) in cables shall not be used (not connected) and the screening of cables shall not be connected to earth.

An Earth Free Zone extends from the basement of the Potrooms to the upper level of the concrete wall which is about 2.5 m from the operation- and service-floors. The building steel structure upon the concrete wall is connected to the earth grid with bare earth wire routed externally.

Figure 1 shows a section drawing of the Potroom and the Earth Free Zone.

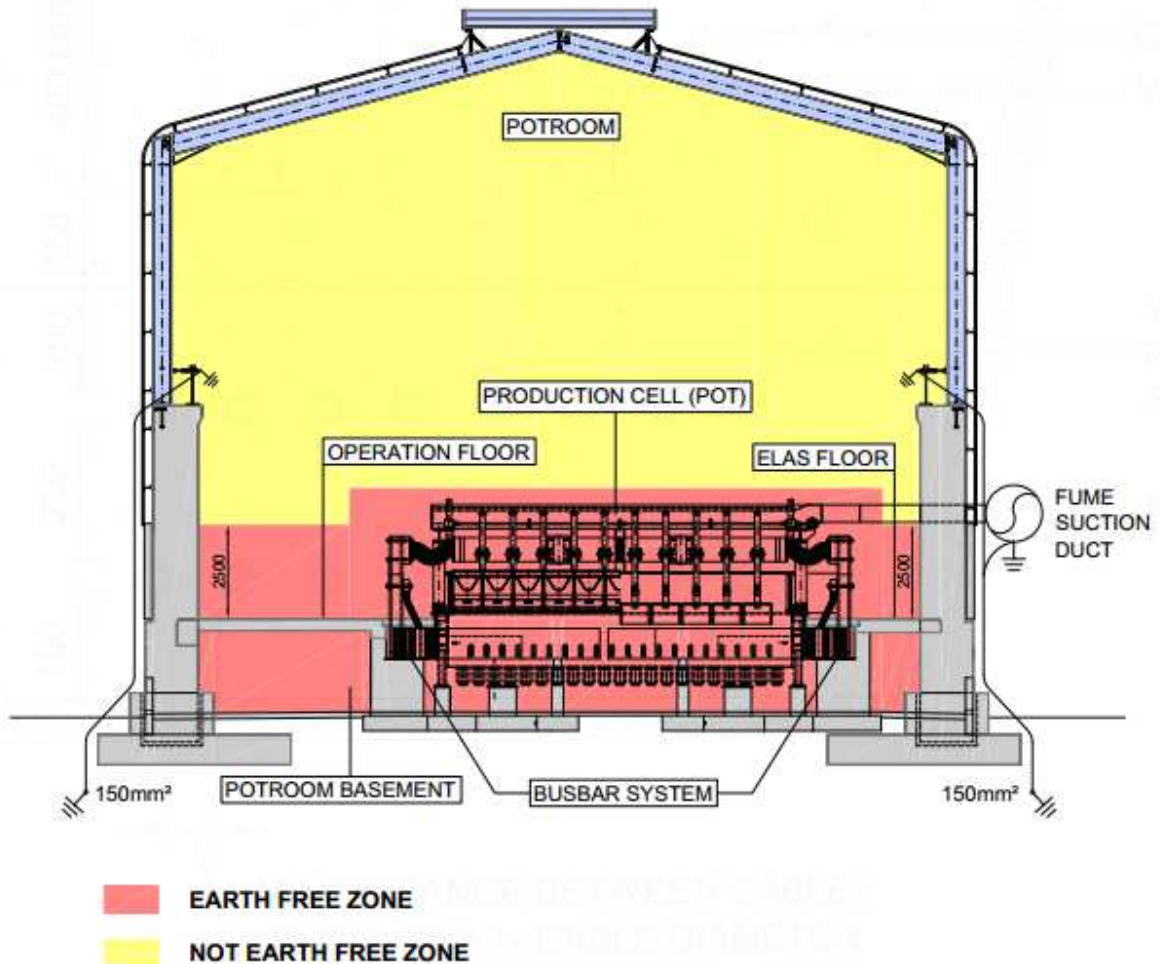

Figure 1 - Typical section of the Potroom

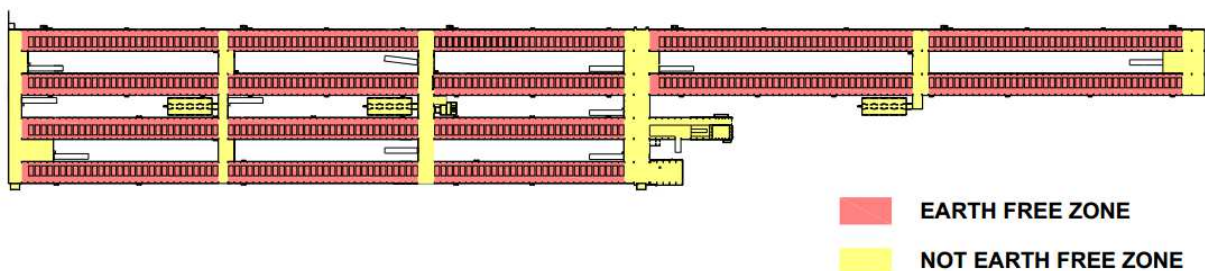

Figure 2 - Overview of the Earth Free Zone in Potrooms operational floor.

All panels and equipment for operation and maintenance shall be isolated from earth and without earth connections. All equipment installed within the Earth Free Zone shall be with suitable mountings to isolate the mounting fixture from the concrete construction. This is to ensure the isolation of the equipment from earth.

### 5.1.2 CABLE ROUTING

The cable ladders and other conducting materials within the Earth Free Zone shall be isolated from earth by segregation as described in section 5.1.1 *Earth Free Zone*.

The cable installation systems mounting brackets within the Earth Free Zone shall be isolated from earth as described in section 5.1.1 *Earth Free Zone*.

### 5.1.3 POWER DISTRIBUTION SYSTEM

It is allowed for power feed cable to pass through the Earth Free Zone. In such an instance the cable and panel or connection box must have supplementary insulation. The isolation of the PE-conductor shall be the same as for the phase conductors.

The PE-connection inside connection box in the Earth Free Zone shall be regarded as a full potential conductor with reference to the environment (Earth Free Zone). The PE-connection shall be marked as such.

### 5.1.4 SOCKET OUTLETS WITHIN THE EARTH FREE ZONE

No earth connected sockets are allowed inside the Earth Free Zone. Sockets inside the Earth Free Zone shall be supplied with an isolation transformer.

All hand tools shall have supplementary insulation (double insulation). Battery operated hand tools are preferred.

It is prohibited to use extension cords inside the Earth Free Zone.

## 6 EARTHING

### 6.1 POTROOM EARTH FREE ZONE

Special attention shall be made to Potroom area regarding the Earth Free Zone, see chapter 5 *Potroom Area - Special Requirements*.

### 6.2 GENERAL REQUIREMENTS

The main earth grid at the plant site consists of a meshed grid under the main substation and the rectifier station. The grid is made of bare 150 mm<sup>2</sup> and 50 mm<sup>2</sup> Cu-wires where the 150 mm<sup>2</sup> Cu-wire is used in the outer edge of the grid.

A 150 mm<sup>2</sup> Cu-wire is laid along both sides of the Potrooms where it is used to earth structures outside the Earth Free Zone (see section 5.1.1 *Earth Free Zone*).

Where this grid is extended, damaged, repaired or relocated, it shall be refurbished with Cu-wire of the same cross section.

Each construction and all equipment shall be connected to the main earth grid with the exception stated in section 5.1.1 *Earth Free Zone*. The design of the connection to the main earth grid is subject to the approval of the Owner.

All earth grid Cu-wires are laid directly in the ground. All earth grid and inaccessible connections (wire-to-wire) are either C-clamp or welded (Cadweld).

All joints and fixings shall be made in an approved manner and shall be designed to allow the passage of fault current without any deleterious effect.

Included in the design of new buildings shall be a minimum 50 mm<sup>2</sup> Cu-wire modulator electrode for the reduction of touch voltage. This modulator electrode shall be laid around the building or construction about 500 mm from the outer wall at a depth of 500 mm.

Connection from earth grid to MDB shall be with minimum of 150 mm<sup>2</sup> Cu-wire. Other connections between earth grid and miscellaneous equipment shall be at least 50 mm<sup>2</sup> Cu.

All power outlets and connectors shall be grounded (exception see 5.1.1 *Earth Free Zone*). All extraneous conducting parts, that are not a part of an electrical installation, shall be equipotential bounded.

All power outlets, connectors and metal construction shall be tested for earth continuity when finishing an installation.

All materials and connection methods shall be approved by the Owner.

### **6.3 ABOVE GROUND EARTH SYSTEM**

The minimum cross section area of the earth wire shall be according to the Icelandic Standard ÍST 200 *Electrical installations of buildings*.

Connections to equipment main earth bars and transformer secondary neutrals shall be made directly to the main earth bar of each building/construction. Guards (steel, plastic tubes, conduits etc.) shall be provided for protection where earth conductors are exposed to mechanical stress or possible damage.

### **6.4 EQUIPOTENTIAL BONDING**

Equipotential bonding of all equipment and electrical conducting building structure shall be ensured. Neither structural steel nor water pipes, separately or jointly, shall be used as an equipotential bonding conductor within the installation.

The main columns of steel structure shall be earthed using continuous Cu-wire connected directly to the main earth bar or main plant earth grid. Foundation bolts of the steel structure shall not be used for connections to the earth system.

The equipotential bonding conductor shall not have a cross-section area less than 16 mm<sup>2</sup> Cu.

All joints and fixings shall be made in an approved manner.

#### **6.4.1 EQUIPOTENTIAL BONDING OF CABLE INSTALLATIONS SYSTEMS**

All cable installation systems (ladders, trays, ducts etc.) shall be equipotential bonded. A 35 mm<sup>2</sup> Cu-wire shall be installed the whole length of the system (without being cut) and properly connected to each section of the system. This connection shall ensure that earth/equipotential bonding of cable installation systems is entirely made up of copper.

It is not necessary to connect the equipotential connection to the parallel running cable installation systems (ladders, trays) if it is installed with cantilever arm and vertical fixing rail from the same manufacturer as the cable ladders or trays and if the material is approved for such a connection.

The final configuration is subject to the approval of the Owner.

### **6.5 EXCLUSIONS**

The earthing of the following is to be discussed during the design stage with the Owner.

- Cathodic protection
- Static earthing
- Computer earthing

## 6.6 EMC REQUIREMENTS

All electrical equipment enclosures shall meet the EMC requirements according to ÍST EN 61000 (EN 61000 / IEC 61000) *Electromagnetic compatibility (EMC)*.

In order to prevent mutual interference coupling, power cables and control-, signal- and communication cables shall be routed separately and a minimum clearance of 200 mm between different cable types shall be maintained as much as possible.

The method of connection of cable screens shall be approved by the Owner.

### 6.6.1 EMC EARTHING OF CONTROL- AND SIGNAL CABLES

The Cu-screen of all control- and signal cables shall be connected to the instrument earth or through EMC cable glands at **the panel end only**.

If a control- or signal cable interconnects two control panels the cable's Cu-screen shall **only be earthed in one panel**.

In general all incoming control-, and signal cables shall enter the panel from the bottom. Cable screens shall be earthed through EMC cable glands when entering a panel. The IP-rating (Ingress Protection rating) of the cable glands shall be equal or better than the panel's IP-rating.

The cable screen is earthed when entering through an EMC cable gland. This earthing of the cable screen is sufficient if the sensor cable terminates at the input terminals of the metering unit  $\leq 1000$  mm after entering the panel. If the cable terminates  $> 1000$  mm after entering the panel the screen must not be disrupted but extended until about 200 mm are remaining to the cable termination. There the screen shall be isolated so that it can withhold the isolation for the highest voltage available in the panel.

## 7 CABLE INSTALLATION SYSTEMS

### 7.1 GENERAL

Cable installation systems include cable ladders, cable trays, ducts, conduits, joints etc.

Plastic sealing shall be fitted to the end of cable ladders, trays and conduits.

Generally all cables shall be laid in cable installation systems.

### 7.2 COMPLIANCE STANDARDS

The cable ladders and trays shall be tested according to standard ÍST EN 61537 *Cable management - Cable tray systems and cable ladder systems*.

#### 7.2.1 CABLE LADDERS AND TRAYS

##### 7.2.1.1 General

Cable ladders and trays shall generally only be used for electrical cabling. No pipes or other installations shall be laid in ladders or trays that are intended for cables unless approved by the Owner.

In general cable ladders shall be used for the main cable routing in the production areas, workshops and storage areas. Use of other cable installation material shall be subject to the approval of the Owner.

All cable ladders and fixing material shall be hot-dip galvanized steel according to corrosion class C-5I in conformity to ÍST EN ISO 12944-2 *Paints and varnishes - Corrosion protection of steel structures by protective paint systems - Part 2: Classification of environments*. All cable trays and ladders shall be fastened on cantilever arms, both for installation on walls and ceilings.

Prefabricated bends, T-junctions and X-junctions are preferred but coupling brackets or "take-off hooks" can be used to fix a cable ladder to another cable ladder at an angle.



When adding or fixing to an existing cable installation system the material used shall be of the same type as in the existing cable installation system structure.

The number of fastenings shall be in accordance with the manufacturer's instructions. All cable ladders and fastenings shall be of the same type. All cable trays shall be designed and installed so that sharp bending of cables is avoided. Supporting structure shall permit adjustment so that the level of the ladder can be adjusted horizontally.

To ensure minimal EMC disturbances, control and power cables shall be separated as possible and if laid in the same cable ladder, the Work provider shall supply a continuous metal dividing strip between them.

The cable trays and ladders shall be designed and installed in such a way as to allow the laying of the cables by lifting it onto the cable ladder and tray. Pulling a cable trough an opening should be avoided as possible.

Cable ladders and trays shall be designed and installed with at least 30% extra space and be capable of supporting a 40% increase of weight.

When going through a fire barrier the cable ladder shall be cut just before and right after the opening of the fire barrier as described in section 8.9.2 *Fire precautions*.

### **7.2.1.2 Design Requirements**

Cable ladders and trays shall be of a standard manufactured material.

The maximum deflection of cable ladder and cable tray supplied shall not be more than 20 mm with a load of 50 kg/m on a 3-meter support span. If cable ladder covers are used they shall be of peak type with 30-degree slope.

### **7.2.1.3 Corrosion protection**

Steel cable ladder, tray and conduit shall be Hot Dipped Galvanized.

Hot Dipped Galvanization shall conform to class C4 according to ÍST EN ISO 1461 *Hot dip galvanized coatings on fabricated iron and steel articles - Specification and test methods*.

In areas polluted with Alumina and Fluoride dusts, cable ladders shall be painted additionally for corrosion protection by Epoxy or similar paint with the minimum thickness of 150 µm. Color shall be according to NA-00-03-TS001 Surface Treatment and Painting. Provisions shall be made to ensure good earth connection when the cable ladder is painted.

### **7.2.1.4 Accessories**

Special accessories from the manufacturer of the cable ladder or tray shall be furnished as required to protect, support, and install a cable ladder/tray system.

Joints shall be such that it may be located anywhere within the support span without diminishing rated loading capacity of the cable ladder or tray.

Barrier strips shall be adequately fastened on to the cable ladder and tray.

In general all cable installations shall be assembled with as few joints as possible.

### **7.2.1.5 Fastenings of cables**

Fastening of cables – see section 8.9.4 *Cables laid on cable ladders and trays*.

## **7.2.2 CONDUITS**

### **7.2.2.1 General**

Conduits shall have ample cross section and wall thickness. Conduits shall have no sharp edges or discontinuities that can damage the insulation of wires and cables.

The installation of conduits shall be in accordance with ÍST 200 *Electrical installations of buildings* and approved workmanlike fashion.

The Owners representative shall inspect all conduit installations before they are covered (made inaccessible).

Conduits shall be hot-dip galvanized steel conduits, aluminum conduits or PVC conduits. The material selection is subject to the Owners approval.

The conduit clamp shall be appropriate for the type of conduit used. It shall raise the conduit approximately 5-15 mm from the surface. The material of the conduit clamp shall suit the material of the conduit with respect to corrosion, appearance etc. The conduit clamp shall support and fasten the conduit so that it does not easily break or come off the conduit clamp.

In general fittings shall not be used with non-covered conduits.

#### **7.2.2.2 Material**

##### **Plastic Conduits**

PE (Polyethylene) or PP (Polypropylene) conduits that are used as part of an electrical installation in buildings shall be manufactured in sections.

PE conduits that are laid underground shall have as few joints as possible.

If the PE and PP conduits are supplied in sections the connection method is subject to the Owners approval.

All PE conduits shall comply with standard ÍST EN 12201 *Plastics piping systems for water supply - Polyethylene (PE)*.

All PP conduits shall comply with standard DIN 8077 *Polypropylene (PP) pipes - PP-H, PP-B, PP-R, PP-RCT – Dimensions*

##### **Steel Conduits**

Steel conduits shall be hot dipped galvanized of rigid construction. Conduits shall be clean with smooth surface, without any projections to avoid damage to the cable.

The conduits shall be supplied in straight lengths.

In areas polluted with Alumina and Fluoride dusts conduits shall be painted additionally for corrosion protection by Epoxy or similar paint with the minimum thickness of 150 µm. Color shall be according to NA-00-03-TS001 Surface Treatment and Painting.

##### **Aluminum conduits**

The material of aluminum conduit shall be anodized aluminum of sufficient thickness. The conduit shall be supplied in straight lengths.

##### **Flexible Metallic Conduits**

Flexible metallic conduit shall be liquid tight, with outdoor weather protection PVC jacket for sealing against water, grease, dirt, and chemicals.

#### **7.2.2.3 Fastening material**

The clamps shall lift the conduit approximately 5-15 mm from the fastening surface. The distance between fastenings of surface mounted conduits shall be such that the conduit does not sag (deflect).

In general all conduits must be fixed in a vertical or horizontal position.

Surface mounted conduits shall be installed in straight sections. In bends and at the connection to equipment the cable is exposed. Fastenings of conduits shall be approximately 100 mm from conduit end.

All fastening material shall be appropriate for the conduits used and is subject to the Owners approval.

## 8 CABLES

### 8.1 GENERAL REQUIREMENTS

#### 8.1.1 GENERAL

The design of the cable installation shall take into account the reliability of the cable installation when redundancy is required. This applies to feeder cables, control cables, signal cables and communication cables.

The cables shall be of manufacturer's standard production and have standardized cross-section. All cables shall be of the metric cable sizes.

All cables shall in principle be laid in one single length. If necessary to extend a cable, approved cable connections shall be used, the Owner informed and the connection documented.

The cables shall be laid in an orderly manner.

Cables in cable ladders shall be fastened properly with clamps or metal cable ties – see section 8.9.4 *Cables laid on cable ladders and trays*.

Neutral- (light blue) and earth- (green/yellow) conductors shall never serve any other than their specific purpose. The neutral in a 3 phase installation shall generally be of the same cross section as the phase conductors.

If required, single core power cables shall be phase identified with bands of colored heat shrink PVC tube, on the outer sheaths.

If required, the Work provider shall supply Low Smoke, Halogen free (LSZH) cables according to section 8.1.2.2.

#### 8.1.2 CABLE REQUIREMENTS

##### 8.1.2.1 General

All cables shall have insulation suitable for the applicable environmental conditions. The conductor insulation shall be made of XLPE or PVC. For areas with local high ambient temperatures, or in fire risk areas, the cables shall be silicone insulated, Teflon insulated or provided with other fire-resistant types of insulation. All cables shall at minimum comply with the fire endurance category standard series of IEC 60332, Test on electric and optical fibre cables under fire conditions.

##### 8.1.2.2 Low Smoke, Halogen free (LSZH) requirement

In some projects within NA plant, at the Owner's request, the Work provider shall supply Low Smoke, Halogen free (LSZH) cables. In these cases the cables shall be fire resistant, flame retardant and fulfill Low Smoke, Halogen free (LSZH) requirements. The cables shall at least comply with, but not limited to, following standards:

- IEC 60331 Tests on electric cables under fire conditions
- IEC 60332 Test on electric and optical fibre cables under fire conditions
- IEC 60754 Test on gases evolved during combustion of materials from cables
- IEC 61034 Measurement of smoke density of cables burning under defined conditions

##### 8.1.3 SCREEN

Cables shall be screened where specified. The connection of the screen must be according to the manufacturer's specifications in order to ensure minimum EMC interference.



## 8.1.4 MECHANICAL PROTECTION AND SEGREGATION OF CABLES

Cables shall generally be routed to avoid hot or fire risk areas, and to minimize the risk of damage from any source. Where necessary, protection from heat or radiation shall be provided.

The cable routing shall be selected in a way to allow a complete segregation of low voltage power cables and of control-, signal- and communication cables. Cable crossings in the same plane shall be avoided.

Armoring may be used for mechanical protection of cables.

When armored cables are used the armor shall be connected as a cable screen as described in section 6.6.1 *EMC Earthing of control- and signal cables*.

Redundant feeding cables (N-1) shall be routed using different cable routes to the equipment.

## 8.1.5 CABLE MARKING

All cables shall be clearly marked.

Cable marking tag shall be in accordance to NA AKS identification system together with NA cable numbering system (*AKS cabinet marking/cable number – XXxxx+XXxx/ABCDEF for example: **UT020+GH22/110307** where **UT020+GH22** is the AKS identification and **110307** is identified according to the following table*). AKS identification for each project will be made in co-operation with the designer and the Owner.

### NA cable-numbering-system: /ABCDEF

The first letter (A) is for area:	Second letter (B) is for:
1 = External work and utility service	1 = Power
2= Personnel and administration	2 = Control
3 = Alumina handling	3 = Ground
4 = Power and electrical distribution	4 = Computer
5 = Aluminum reduction	5 = Telephone
6 = Anode production	6 = Device
7 = Aluminum casting	7 = DC
8 = Environmental control	8 = Fire alarm system
	9= Other alternatives

The last four letters (CDEF) are running numbers

All cables shall be marked at both ends of the cable. Where cable length is within 1.5 m between connection points and the cable routing is clearly visible, one marking tag for the cable is accepted.

The cable marking tag system for the plant shall be of metal durable type. In special electrical rooms within the production area and in administration and personnel facilities, a plastic self-sealing cable marking tag system with engraved markings is accepted.

All cable marking material/system is subject to approval by the Owner.

## 8.2 400 V AC CABLES

The 400 V cables shall be manufactured in accordance with relevant standards. The 400 V cables shall have PVC (Polyvinyl Chloride) or XLPE (Cross-Linked Polyethylene) insulation.

The standard low voltage cables shall comply with the following:

Rated voltage:	600/1000 V (1.2 kV). Minimum category A system in accordance with BS6387.
Conductors:	Class 2 stranded copper up to and including 16 mm <sup>2</sup> and aluminum 25 mm <sup>2</sup> and more.
Conductor area (min):	According to ÍST 200
Conductor insulation:	PVC or XLPE
Conductor identification:	In accordance with SAM HD 308 S2 1 core: Green/Yellow, Blue, Brown, Black or Grey 2 cores: Blue, Brown 3 cores: Green/Yellow, Brown, Blue 4 cores: Green/Yellow, Brown, Black, Grey 5 cores: Green/Yellow, Brown, Black, Grey, Blue
Cable sheath type:	In accordance with section 8.1.2
Cross section of N- & PE-conductors:	Same as the phase conductor for all 4 and 5 conductor unscreened cables.  In screened cables the screen shall be used as a PE-conductor.
Standard cables:	As a general criterion the cables shall be multi-conductors up to 300 mm <sup>2</sup> .  Other single or multi-conductors cable cross sections are subject to the approval of the Owner.

Flexible LV cable shall be used for safety isolation switches to equipment's, mobile equipment and devices that are subject to vibration.

Cables for motors fed by **Variable Speed Drive VSD**, in size equal to and up to 25mm<sup>2</sup>, shall be **Ölflex Classic 135 CH BK 0,6/1KV**. Cables for motors fed by VSD in size over 25mm<sup>2</sup> shall have characteristic similar as possible as *Ölflex Classic 135 CH BK 0,6/1KV*. All variation for cables for motors fed by *Variable Speed Drive VSD* within above stated range is subject to approval by the Owner.

### 8.3 DIRECT CURRENT CABLES

The 110V DC feeder cables shall be manufactured in accordance with relevant standards. The braided screen shall cover 80% of the inner cable sheath to withhold EMC protection.

The 110V DC cables shall comply with the following requirements:

Rated Voltage:	600/1000 V (1.2 kV). Minimum category A system in accordance with BS6387.
Conductors:	Annealed E-copper according to HD 383 S2
Conductor area (min):	2.5 mm <sup>2</sup>
Conductor insulation:	PVC or XLPE
Conductor identification:	2 cores, Unearthed system: Black (+), Grey (0V)
Screen:	Tin coated annealed copper braid with 80 % coverage
Cable sheath type:	In accordance with section 8.1.2

## 8.4 CONTROL- AND SIGNAL CABLES

The control- and signal cables shall be manufactured in accordance with relevant standards. The insulation of the conductors shall be black and each conductor shall be marked with a white colored number or vice versa running all the length of the conductor insulation. The inscriptions shall be easily legible and durable. The insulation of conductors may also be colored instead of numbered for identification.

Generally, all control- and signal cables shall be screened with a tin coated copper braid. The screen shall be terminated as described in section 6.6 *EMC Requirements*. When signal cables are only carrying digital signals, unscreened cables may be used with the written approval of the owner.

The routing of control- and signal cables from EMC terminations within panels to terminal blocks shall be with the inner sheath on.

All cables for data links shall be selected for their specific use. All signal cables that carry analogue measurements (e.g. 0 - 20 mA, 4 - 20 mA and Pt100) shall be of the twisted-pair type.

Rated Voltage	300/500 V. Minimum category A system in accordance with BS6387.
Conductors:	Fine stranded annealed copper
Minimum conductor area	0.5 mm <sup>2</sup> if control/digital cable 0.5 mm <sup>2</sup> if signal/analogue cable 1.0 mm <sup>2</sup> for main electrical feeding to control units.
Conductor insulation:	According to application
Conductor identification	Numbered black cores Numbered white cores Color coded Earth connector green/yellow
Screen	Tin metal-coated annealed copper braid
Cable sheaths type	In accordance with section 8.1.2

## 8.5 FIRE DETECTION AND ALARM CABLES

### 8.5.1 GENERAL

The Fire detection and alarm cables shall be manufactured in accordance with relevant standards and in accordance with section 8.1.2 in this standard. They shall fulfill the requirements of the following table.

	Non addressable detector device	Addressable detector device	Signalling device cable	Fire bus connection cable
Multicore (2, 4 or 7 conductors)	X		X	X
Single twisted pair covered with aluminum/polyester Mylar tape screen with drain wire		X		
0.5 mm <sup>2</sup> cross sectional sizes with PVC insulation				X
1.5 mm <sup>2</sup> cross sectional sizes with XLPE insulation	X	X		
2.5 mm <sup>2</sup> cross sectional sizes with XLPE insulation			X	
Up to 80 °C minimum normal temperature operation with occasional flexing				X
90 °C minimum normal temperature operation	X	X	X	
Stranded copper conductors	X	X	X	X
Overall screen		X		X
XLPE insulation, 90 °C minimum normal temperature operation	X			
Rated voltage 300 V minimum	X	X	X	
Outer sheath marked each 1 m	X	X	X	
Cable jacket (sheath) shall be minimum 1.2 mm	X	X	X	
Sheath color shall be RED	X	X	X	
Sheath color shall be BLACK				X

## 8.6 ETHERNET TWISTED PAIR CABLES

### 8.6.1 GENERAL

The Ethernet cables shall be in accordance with the following standards.

- EIA/TIA 568 B.2 *Transmission requirements*
- ISO/IEC 11801-2<sup>nd</sup> *Cabling standard*
- IEC 61156-5 *Multicore and symmetrical pair/quad cables for digital communications*
- ÍST EN 60332-1 *Tests on electric and optical fiber cables under fire conditions*
- IEC 60754-2 *Test on gases evolved during combustion of materials from cables*
- ÍST EN 61034 *Measurement of smoke density of cables burning under defined conditions*

Each network segment shall have a maximum length of 100m (the permanent link overall length must not exceed 90m).

Installation: To maintain transmission performance of the Ethernet installation system, the Ethernet cable configuration must be maintained as close to the point of termination as possible. The maximum untwists of 13 mm (0.5 inch) from the point of termination.

Testing and installation report shall submit to the Owner in pdf format showing all measured links.

### 8.6.2 CAT5-E UTP

Cat5-e UTP cable shall be used for connection the Ethernet network system.

<b>Specification</b>	
Sheath	In accordance with section 8.1.2
Cable diameter	5 ±0.2 mm (nominal)
Cable bend radius	4 x diameter (no load/ loaded during installation)
Max tension	100 N
<b>Electrical characteristics</b>	
Conductor DC resistance	≤ 9,4 Ω/100 m @ 20 °C
Mutual capacitance	≤ 50 pf/m
Worst case cable skew	25 ns/100 m
Nominal velocity of propagation	75%
Characteristic impedance	100 ±15% Ω

## 8.7 FIBRE OPTIC CABLES

### 8.7.1 GENERAL

The fiber optic cables shall be manufactured in accordance with relevant standards.

Fiber optical cables used between buildings (backbone) shall be of the single-mode type and within buildings of the multi-mode types, with non-metallic rodent protection and full water-blocking properties. Single-mode cable shall be used inside buildings where distances are more than 850 m, such as in the Potroom. All single mode fiber optical cables used in the installation shall be of the same type and have the same number of fibers. All multi-mode fiber optical cables used in the installation shall be of the same type.

All fiber optic cables can be laid in cable ladders, trays, ducts or routes alongside low voltage cables if convenient. The installation the fiber optic cables shall allow an easy replacement of the fiber optic cable.

Terminations shall be of manufacturer's standard production. The type of terminations used shall be subject to approval by Owner. The cables shall be all-dielectric with tensile strength of at least 1000 N.

Fused cable splicing shall be used where necessary. Splice closure and strain relief shall ensure no loss of strength or protection at splice joints.

All fiber optical links shall be tested with OTDR and Power Loss instruments after installation to provide test results for light source and power testing of all fibers with the identification of fiber length and core color. These tests shall be witnessed by the Owner. The results of the testing shall be shown to be within the manufacturers specifications.

All tests results shall be recorded and included in a written report and submitted to the Owner.

Documentation of the installation information, such as on pulling eye, coating removal and splicing, material safety data sheet, cable and fiber test sheets and detailed cable technical specifications shall be submitted to the Owner. Included in the submittal shall also be documentation of the tests results for all pre-made pigtails and patch lease used shall be provided.

Testing and installation report shall submit to the Owner in pdf format showing all measured optical links.

## **8.7.2 MULTI MODE FIBRE**

### **8.7.2.1 General**

Multi-Mode fiber optic cables shall be guaranteed for Gigabit Ethernet transmission at least up to 300 m at 850 nm (OM3).

### **8.7.2.2 Indoor/ outdoor fiber specification**

- Fiber type ..... (50/125  $\mu$ m)
- Attenuation: 850 nm .....  $\leq 3.5$  dB/km
- Attenuation: 1300 nm .....  $\leq 1$  dB/km
- Modal bandwidth: 850/1300 nm ..... 500/500 MHz – km

### **8.7.2.3 Indoor/ outdoor cable specification**

Graded index cable type, non-metallic, tight buffered multitube distribution cable for horizontal cablings. Jacket material according with section 8.1.2 in this standard. Glass-roving strain relief and rodent protection.

Dry construction with full water blocking properties.

### 8.7.3 SINGLE MODE FIBRE

#### 8.7.3.1 Fiber specification

- Single mode ITU G.652.D compliant and in addition
- Maximum attenuation at 1310nm: ..... < 0.36 dB/km
- Maximum attenuation at 1550nm: ..... < 0.23 dB/km
- Attenuation coefficient of continuous 1 km length shall not vary ..... > 0.05 dB/km
- No point discontinuities in excess of ..... 0.10 dB
- Zero dispersion wavelength range: ..... 1300 nm to 1322 nm

#### 8.7.3.2 Cable specification

- All – dielectric, metal free, indoor/ outdoor or duct, fiber cable jacket according with section 8.1.2 in this standard.
- Glass yarn
- Multi tube, loose tube design, non-metallic, dry core, gel free with central strength member.
- Fiber coloring code:.....TIA/EIA-598-C.
- Water protection tested in accordance with IEC 60794-1-2-F5B
- Jacket: Polyethylene single jacket suitable for air blown fiber in pipes (HDPE or PA-12).
- Maximum cable bending radius:..... 15X (installation), 10X (operation).
- Maximum tensile loading during installation: .....  $\geq 2.5$  kN
- Maximum tensile loading operation: .....  $\geq 600$  N
- Crush resistance, short term (plate/plate):.....  $\geq 2$  kN/10c m
- Temperature:
  - Installation: ..... - 10 °C – + 50 °C
  - Operation:..... - 40 °C – + 60 °C
- Rodent proof armoring: ..... Level 1 or better

### 8.8 POWER CABLES

Selection of power cables shall be in accordance with ÍST 200 *Electrical installations of buildings* and the following demands:

- Short circuit capacity (section 8.8.1 *Short circuit capacity*)
- Continuous current carrying capacity (section 8.8.2 *Continuous current carrying capacity*)
- Voltage drop (section 8.8.3 *Voltage drop*)

The largest cross section of cable as determined from the points above shall be used.

The design conditions limiting these factors shall be as stated in the following sections.

### **8.8.1 SHORT CIRCUIT CAPACITY**

Information of the short circuit capacity of MDB's and DB's is supplied by the Owner.

Design and dimensioning of the cables and terminations with regard to mechanical and thermal short-circuit withstand shall be in accordance with *ÍST EN 60909 Short-circuit currents in three-phase AC systems* and *ÍST EN 60865-1 Short-circuit currents - Calculation of effects - Part 1: Definitions and calculation methods*.

### **8.8.2 CONTINUOUS CURRENT CARRYING CAPACITY**

The current carrying capacity of cables shall be in compliance with *ÍST 200 Electrical installations of buildings*.

Normally, the cable installation shall be designed such that no cable shall carry a current in excess of 70% of what is stated in *ÍST 200 Electrical installations of buildings*.

Connections from the secondary winding of MV transformers shall be sized for the transformer rated capacity.

Connections to and from MCC (Motor Control Cubicle) shall be sized according to the bus rating of the MCC's.

### **8.8.3 VOLTAGE DROP**

Calculations of voltage drop shall use the respective nominal system voltage, the maximum impedance of each component and the full load current of each cable in the distribution network. At each voltage level the size of conductors shall be such that the maximum voltage drop in the cable for both AC and DC circuits will be:

- 1) Between the main board and final equipment (startup currents for large motors - see item 4 below):
  - 5% when using full load current
- 2) Between the main board and final sub-distribution board, using the sub-distribution board busbar rated current:
  - 1% if both are in the same room and
  - 2% otherwise
- 3) Between the final sub-distribution board and final equipment or most distant load:
  - 3% when using full load current
- 4) Between the final sub-distribution board and a motor during motor startup.
  - 15% when using motor startup current

## **8.9 INSTALLATION OF CABLES**

### **8.9.1 GENERAL**

The cables shall be laid and fixed, in a way to avoid any damage to their insulation. Special precaution shall be taken to avoid mechanical damage of the cables outer insulation when exiting floor ducts, pipes and trenches. Where cables are exposed to mechanical stress, sheet-steel guards shall be provided for protection. If considered necessary, cables in production areas (including those on cable ladders and trays) within 3 m of floor level, shall be provided with additional mechanical protection (shield, cover). Cables shall never be fixed directly on surfaces.



All cables installed outdoors shall be UV-resistant according to ÍST EN ISO 4892-2 *Plastics - Methods of exposure to laboratory light sources*. Ventilated covers shall be installed if protection against sun radiations is needed.

The cables shall be laid in an orderly manner. Cable crossings in the same plane shall be avoided. Cable routing shall ensure that the bending radius of each cable does not exceed the manufacturer's recommendations.

The layout of all cables shall be arranged so as to have adequate clearance from other services. Control cables shall be separated from power cables and shall not be laid on the same cable ladder or tray without segregating the cables – see section 8.9.3 *Segregation*.

Cables shall not be laid over protruding parts or edges, bent or twisted in a way that might later cause damage. Short lengths may be run in steel conduits

All cables shall be installed either on cable ladders or trays, in conduits, in ducts, laid in concrete trenches or directly buried in ground.

### **8.9.2 FIRE PRECAUTIONS**

Enclosed vertical runs of cables shall be provided with fire stops in order to limit the spread of fire, and shall be sealed to prevent "chimney effects".

Wherever cables pass through floors, walls or other partitions, a suitable method of sealing shall be used. This sealing shall withhold the fire barrier properties of the respective floor, wall or other partitions. The fire sealing shall be installed by a qualified person. Each fire sealing shall be marked with date, fire barrier properties and initials of the fire barrier installer. Those who undertake to implement fire sealing shall be authorized as such and have the approval of MVS (Mannvirkjastofnun) based on local regulation no. 1067/2011.

A part of fire precautions is to cut the cable ladder, tray or conduit just before and right after going through the opening of the fire barrier.

### **8.9.3 SEGREGATION**

Cable installation systems (ladders, trays, ducts etc.) that share the same location and voltage range are defined in the following table which shows the corresponding vertical and horizontal separations for horizontal ladders and trays.

Cables that are installed side-by-side but have a different voltage range shall be installed with segregation according to the following table. This applies in all cases when considered practical.

Voltage range or cable used	Vertical separation of trays/ladders (bottom of tray to bottom of tray, mm)	Horizontal separation of trays/ladders <i>See Note 1 at the bottom of table</i>
6/11 kV	Top most	
230 to 400 V AC <i>See Note 2 at the bottom of table</i>	450 mm	150 mm
24 V DC, Fiber optic, Communication	600 mm	150 mm
Fire	0 mm or same ladder/tray as above with barrier.	150 mm or same ladder/tray with barrier.
<p><i>Note 1: This horizontal separation only applies to a set of 2 trays in the same horizontal plane. If there is a third one its separation from the closest one must be 450 mm. This is the empty space required on either side of a tray to allow construction personnel to lay cables.</i></p> <p><i>Note 2: Low voltage cables linking VSDs to motors shall be segregated from other cables by a barrier.</i></p>		

#### 8.9.4 CABLES LAID ON CABLE LADDERS AND TRAYS

Control cables and other cables belonging to the same category (communication, fiber optic, etc.), may be bunched on appropriate cable ladders or trays.

Permanently installed cables on cable ladders or trays, horizontal or vertical, shall be fastened with metal straps. If the metal strap is PVC coated the minimum size of the strap is 8 mm, if not PVC coated then minimum size is 10 mm. The fastening of the metal straps shall in all instances be perpendicular (IS: hornrétt) on the cable. Fastening clamps (IS: krókspennur) can be used on vertical runs instead of metal straps.

For reference, the distance between cable fastening on cable ladders or trays shall be:

- For vertical ladders or trays, approximately **300 mm**
- For horizontally ladders or trays, approximately **600 mm**

#### 8.9.5 CABLES LAID IN CONDUITS

In general no cable conduits are to be laid in ducts or trenches with other services such as oil pipes, steam or hot water pipes, etc. unless approved by the Owner.

The handling and finishing regarding conduits laid underground shall generally be executed in the same way as cables laid directly in ground – see next section (8.9.6 *Cables laid directly in ground*).

#### 8.9.6 CABLES LAID DIRECTLY IN GROUND

Where cables are to be laid directly in ground, they shall be placed in the center of a straight trench. Earth conductor shall be laid at the bottom of the trench if used. A layer of fine riddled sand shall be placed at the bottom of the trench over the earth wire and before the cables are laid. The layer shall be compressed to a finished thickness of approximately 150 mm.

After the cables have been laid in the trench, they shall be covered with fine riddled sand, compressed over and around the cables to a height level of approximately 150 mm above the top of the cable.

The fine riddled sand shall be analyzed with regard to the thermal resistivity [Km/W] and is subject to the Owner approval.

Ample sized cable conduits shall be used where cables:

- cross a road
- are in danger of being mechanically damaged after installation
- at other locations where the cable laying may can be at risk

A plastic shield shall then be placed over the cables as indicated by Figure 3. This shield shall be PE materials with a minimum width of 150 mm.

Warning ribbons with appropriate text inscription (e.g. IS: Varúð – lágspennustrengur (Warning - Low Voltage Cable)) shall then be placed above the PE plastic shield as indicated in Figure 3.

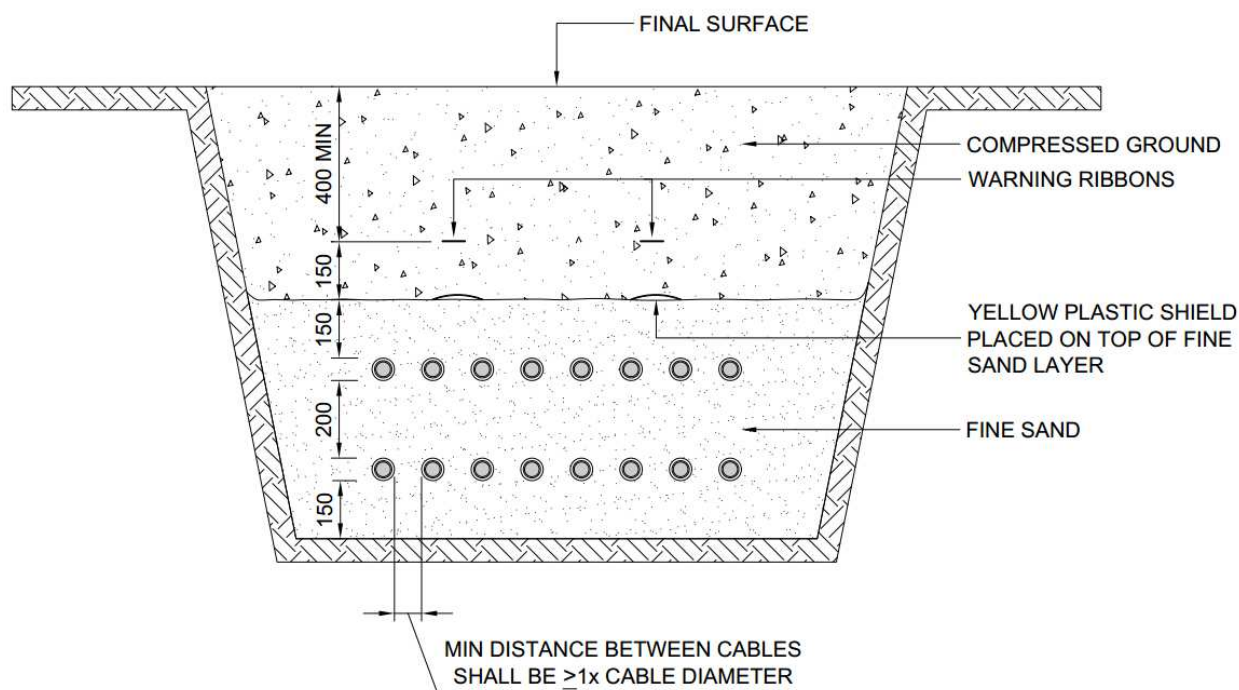

Figure 3 - Typical section of cable trench

The filling in of trenches shall not be commenced until the Owner has inspected the cables in the trenches. Back filling shall proceed in 150 mm layers, each layer being well consolidated (compressed) before the next is added. Markers shall be used as specified.

### 8.9.6.1 Depth of laying

The depth upon underground LV cables shall not be less than 700 mm under final surface.

### 8.9.6.2 Cable records

All underground cables, cable joint, draw pits (manholes) and conduit shall be surveyed and submitted to the Owner. The measuring methods that can be used are GPS survey, measuring with Total station, leveling instrument and measuring tape, or any other method suitable for the work.

The National Land Survey of Iceland (IS: Landmælingar Íslands) has in cooperation with municipals and public serving companies produced a procedure for survey and data handling (IS: Innmæling / Útsetning – Verklagsreglur fyrir innmælingar og útsetningar). This procedure

shall be used as a guideline for all survey and data handling. The publication can be found on the LMÍ (Landmælingar Íslands) website [lmi.is](http://lmi.is).

NA uses a local grid system for the plants locations. All data shall be delivered in respective coordinates system, unless otherwise decided by the Owner.

All survey data shall be supplied to the Owner in form of comma delimited file (csv) according to above procedure and in an AutoCad file (dwg) in a right coordinate system with a mark (cross or other marking) annotated with point name and point code in a readable manner. All survey data shall be in meters.

### **8.9.7 CABLE TERMINATION**

XLPE cables, which are not to be terminated on the day of cutting, shall be sealed in an approved watertight and airtight manner to prevent deterioration of the cable insulation.

All cables shall be suitably clamped near the point of termination, glanded on entry to the equipment or terminal so that neither the IP-rating nor the EMC compliance of the enclosure is affected. Cable glands shall be metric glands appropriate for use with armored and unarmored circular cables. Proper glands shall be used to terminate shield wires on enclosures according to section 6.6.1 *EMC Earthing of control- and signal cables*.

All main power cables shall be terminated using crimp-type cable lugs if appropriate, in compliance with the following requirements:

- Lugs for cables up to and including 6 mm<sup>2</sup> shall be of the pre-insulated type or other type approved by the Owner. All control cables shall be terminated using lugs or pins of pre-insulated type as required
- Heat shrink sleeve shall be applied to lugs which are not of the pre-insulated type. Use of electrical tape is not accepted for this application
- All lugs shall be crimped using compression tools of the correct size and type
- The correct size and type of lug shall be used in all terminations. Oversized diameter lugs shall not be used
- Pin type depression crimpers shall not be used

All terminations of control cables in junction boxes and panels shall be made using suitably fixed terminal blocks. No more than one wire shall be terminated into any one terminal.

Cables shall be terminated using the best practice that prevent EMC-disturbance.

#### **8.9.7.1 Termination and ferruling of control and signal cables**

External sheathing shall be stripped back to the point the cable enters the termination enclosure. Initial installation shall allow sufficient length of cable to permit re-termination. The preferred arrangement is for cable wires to be cut such that each wire can reach the most distant terminal in the relevant terminal strip.

All wires of control- and signal cables shall be terminated in terminals at both ends of the wire. The screen drain wire of signal cables shall be fitted with clear insulating tubing.

Screen drain wires for signal cables shall be terminated to an earthed terminal at the panel end.

In marshaling boxes, screens shall be cut off at the end of the cable bedding, and drain wires shall be fitted with clear insulating tubing. The exposed screen at the end of the bedding shall be insulated with heat shrink sleeve. Drain wires shall be connected at dedicated terminals to ensure continuity of the screen shielding system (earth or equipment earth).

At the field equipment, the screens and drain wire shall be cut off at the end of the cable bedding and the exposed screen at the end of the bedding shall be insulated with heat shrink sleeve.

The requirements for earthing of protective screens may vary and care shall be taken to comply with the design requirements in each case.

Control, signal- and communications cables can have label fitted to each wire. Label marking shall be in accordance with the drawings. The wire label marking and type of ferrules are subject to the approval of the Owner.

### **8.9.7.2 Termination of Communication Cables**

The termination of communication cables shall be in accordance with any specific requirements applicable. Communications cables shall be terminated generally as described above see section 8.9.7.1 *Termination and ferruling of control and signal cables*, with the exception of removal of the outer sheath. The length of cable stripped out of the outside sheath and protective shield for termination shall be kept to a minimum and the twisting of the pairs shall continue up to the terminals.

Where there is a requirement to fit a plug or terminating device to a communications cable, this shall be in accordance with the relevant instructions and performed by skilled personnel. Care shall be taken to earth the shield or screen in accordance with the relevant instructions. General practice shall be to make the screen continuous along the communications link and earthed at one end only.

## **9 PANELS**

All panels shall be manufactured according to the appropriate ÍST, EN and IEC standards (see 3.1 *References*), along with this Standard Technical Specification.

All panels shall be standardized panels.

Panels shall be constructed, implemented and tested according to IST EN 61439.

All materials supplied shall be certified for the purpose for which they are to be used.

All materials, panel type, construction and finish, along with single-line diagrams are subject to approval by the Owner.

### **9.1 PANEL CLASSIFICATIONS**

Electrical panels are categorized in this Standard Technical Specification as follows:

- Main Distribution Board – MDB
- Motor Control Center – MCC
- Distribution Board – DB

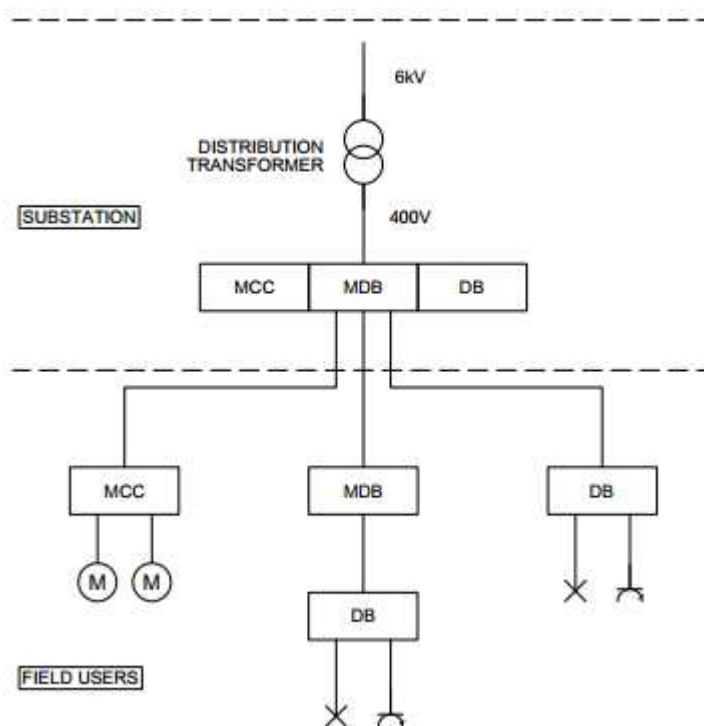

Figure 4 - Typical configuration of panels

### 9.1.1 MDB – MAIN DISTRIBUTION BOARDS

MDBs are specified in this Standard Technical Specification as main low-voltage electrical power distribution panels. MDBs control and distribute electrical power from distribution transformers or substations to other MDBs, DBs or MCCs (see 9.1.2 *MCC – Motor Control Centers* and 9.1.3 *DB – Distribution Boards* respectively) in specific buildings or building-sections within NA work area.

Generally all outgoing feeders from MDBs are Molded Case Circuit Breakers (MCCBs, see section 10.1.2 *MCCB – Molded Case Circuit Breaker*).

### 9.1.2 MCC – MOTOR CONTROL CENTERS

MCCs are specified in this Standard Technical Specification as assemblies of one or more enclosed sections having a common power bus and principally containing motor control units. MCCs are fed from MDBs (see 9.1 – *Panel classifications* and 9.1.1 *MDB – Main Distribution Boards*) and can include variable speed drives (VSD), programmable controllers and metering.

### 9.1.3 DB – DISTRIBUTION BOARDS

DBs are specified in this Standard Technical Specification as LV electrical power distribution sub-panels, generally fed from MDBs. DBs distribute electrical power to equipment such as lights, sockets outlets and other small electrical loads within the DB's specified section or area.

Generally all outgoing feeders from DBs are Miniature Circuit Breakers (MCBs – see section 10.1.3 – *MCB – Miniature Circuit Breakers*).

### 9.1.4 PANEL CONSTRUCTION

All panels shall be of the metal clad type. They shall be suitable for free standing or wall mounting depending on the application. The maximum height of panels shall not exceed 2150 mm including the base frame.



Floor standing panels shall have at least 100 mm base frames. The fastening of the panel shall be secure and be able to tolerate the environmental effects expected in the area with respect to vibration, dust and erosive environment.

Panels IP-rating shall be IP3X or higher indoors in clean areas (i.e. special electrical rooms) and IP65 or higher in areas with harsh environment or outdoors.

Doors shall be capable of being opened at least 120 degrees. All doors shall be provided with locking facilities.

The design of panels shall include 20% spare space. Cable fastenings and mounting plates shall be included in the spare space.

All equipment shall be securely fixed. Equipment removal must be easy from the front of the panel. It is not allowed to mount equipment to the bottom, top or to the sidewalls of the panel except the panel's accessories. All apparatus shall be mounted in such a manner as to permit easy access to all components.

The design of the panel configuration is subject to the approval of the Owner.

### **9.1.5 INTERNAL PROTECTION**

All electrical equipment installed inside a LV panel shall be IP2X ensuring that access cannot be gained to bare and "live" conductors.

Shields can be used to obtain IP2X of electrical equipment.

### **9.1.6 INTERNAL SEPERATION**

No pneumatic or hydraulic equipment or pipe work is allowed in electrical panels.

All panels shall be arranged in such a way that under full load conditions, with all doors, covers and compartments closed, cooling is sufficient.

Where as MDB and MCC panels are attached panels (linked together as one panel), in substations, the panels shall be type tested and arranged in accordance with Form 4a of IST EN 61439 and generally contain the following compartments:

- Busbar compartment
- Cable compartment
- Circuit breaker compartment including contactor
- Measuring device and/or control equipment compartment

Compartments shall be spacious enough for the equipment which they are to accommodate.

The form of MDB's and MCC's are subject to the approval of the Owner.

#### **9.1.6.1 Busbar compartments**

Busbar compartments shall contain the L1, L2, L3 – busbars and alternatively the N-busbar.

Access to all busbar compartments should be provided by bolted type covers.

#### **9.1.6.2 Cable compartments**

Cables shall enter the relevant cable compartment from the bottom. If a panel is situated outside the clean environment of distribution stations or substations the cable intakes at the bottom of the panel need to be protected to uphold the protection code of the panel – see 9.1.4 *Panel construction*.

If a cable compartment serves a singular row of circuit breakers to the right or left, the compartment shall be of minimum width 400 mm. If a cable compartment serves two rows of circuit breakers, one on each side, the compartment shall be of minimum width 600 mm.

Each cable compartment shall contain a vertically placed PE – bar that connects to a horizontally placed PE – bar at the bottom of the panel. Connection equipment shall be positioned on the vertically placed PE – bar in each cable compartment.

Each cable compartment shall contain fastening rails that are placed across the width (at the bottom) and depth on both sides of the cable compartment for cable fastening. The vertical space between the rails shall be no more than 350 mm.

#### **9.1.6.3 Circuit breaker compartment**

The breaker handles of MCCBs rated  $\geq 40$  A and above shall be taken through the doors/covers of their respective compartment. These handles shall be placed in such a way that their position is in line with the single line diagram on the door/cover – see part 9.1.7 *Panel finish*. The handle's "ON", "OFF" or "TRIP" position shall in that way be a part of the single line diagram and show if the circuit within is closed or open.

If MCB's for distribution, lighting etc. need to be a part of MDBs or MCCs, they shall be in special compartments, considered as DBs within MDBs.

#### **9.1.6.4 Measuring device and/or control equipment compartment**

If measuring equipment or other comparable equipment is needed it shall be fitted in panel doors/covers of the measuring device and control equipment compartment – see section 10.11 *Marking and labeling of equipment*.

Generally, motor "START/STOP" switches shall NOT be mounted in or on MCCs. There shall however be pilot lamps with LED bulbs mounted on the front covers/doors that indicate the status of their respective Motor Protection Circuit Breaker.

VSD, frequency converters shall generally be located in or near MCCs.

Motor controllers shall be positioned in special, individual compartments in larger types of MCCs.

The design of VSD frequency converters arrangement is subject to the Owners approval.

#### **9.1.7 PANEL FINISH**

The color of the exterior finish is to be RAL 7035 – Mild grey or similar and shall be subjected to approval of the Owner.

A mimic diagram (single line diagram) of the electrical MCB board configurations shall be fixed onto the front of the circuit breaker compartments covers that show the circuit arrangement within the board. These diagrams shall be permanently marked onto the front of board.

When making cutouts for meters or other equipment e.g. in the door of the panel the edge must be treated with paint or other measures to prevent it from rusting (corroding).

#### **9.1.8 PANEL AND EQUIPMENT LABELING**

A sign shall be fixed on every panel and circuit breaker in the panel. The lettering of the sign shall be according to the example as shown in figure 5.

The sign shall be made of a durable white approx. 3 mm thick plastic material engraved with black lettering.

The sign shall be fixed to the panel either with adhesive or screws.



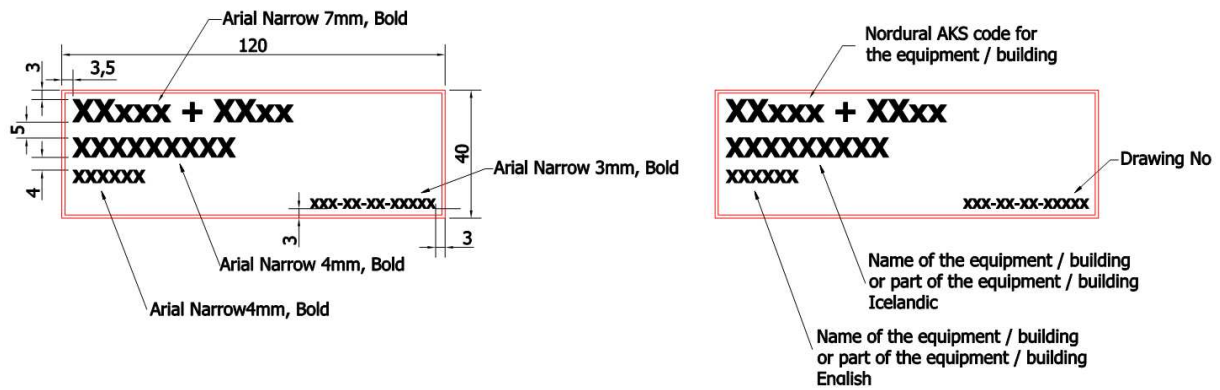

Figure 5 - Example of a panel labeling

### 9.1.9 PANEL ARC FAULT PROTECTION

Panel arc fault protection requirements can be seen in section 4.1.4. *Arc fault protection.*

## 9.2 PANEL ACCESSORIES

In general the panel design shall include illumination and socket outlet of the interior of a panel. This shall be decided on in co-operation with the Owner. In general internal lights shall be controlled by door switch.

Where electrical feeding (230V) connection for the illumination and the socket outlet is generated from the main incoming feeding cable, prior to the incoming feeding cable connection to main circuit breaker for the panel, the power feeding wires for the illumination and the socket outlet shall be double insulated. Also, if this installation is conducted within the panel then the following warning marking, see figure 6, shall be placed next to the feeding circuit breaker for the illumination and the socket outlet.

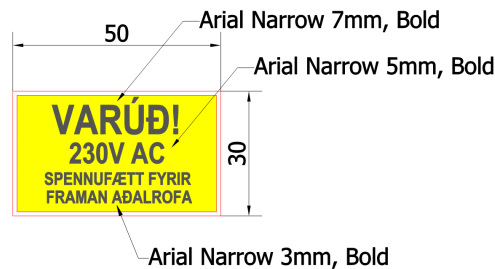

Figure 6 - Warning labeling

Low watt panel heaters are to be provided to prevent condensation in the interior part of all panels if considered necessary. These heaters shall be suitable for 230 V single phase, 50 Hz, AC supply and controlled by a thermostat.

## 9.3 ABNORMALITIES

The structural support and fastening of the heavy equipment shall be sufficient to assure a secure operation and is subject to the Owner's approval.

It might be necessary to create ventilation or cooling system for the equipment inside the panel if heat accumulates within panels. The method of cooling shall be chosen according to the surrounding of the panel i.e. dust, damp and is subject to the Owner's approval.

## 9.4 NAMEPLATES

All panels shall be fitted with approved NA identification plate at the front permanently affixed thereto. NA will supply the text of the identification plate – see section 9.1.8 *Panel and equipment labeling.*

Each panel shall have a nameplate showing in a legible and durable manner the name of the manufacturer/assembler, the rated capacity of the busbars (nominal and short circuit capacity) and voltage system.

Nameplates shall be made in accordance with the nomenclature and units of measurement used in the metric system (SI-units). .

## **9.5 EARTHING AND BONDING OF PANELS**

The steelwork of the panel and, in particular, the gland plate must be solidly and effectively bonded to the main earth bar. It is only allowed to have one earth wire under each bolt or screw on the earth bar.

The connection point of a PE conductor to the support strip (DIN rail) of a terminal group shall be in the middle of the strip or at both ends if the length of the strip exceeds 1 m.

All panel parts shall be equipotential bonded.

## **9.6 BUSBARS**

Main busbars shall be fixed on "Non Tracking" insulators at suitable intervals to withstand the dynamic forces under short circuit conditions of at least 50 kA -  $I_{th}$  (1s).

Phase arrangements shall be L1-L2-L3 from top to bottom, from back to front and from left to right when facing the front of the panel. Busbars shall be clearly marked.

Subsidiary busbars connecting individual panel parts to the main busbars shall be designed for the same short circuit conditions as the main busbars.

Equipment shall not be mounted directly on the PE-busbar.

## **9.7 CABLE ENTRIES**

The cable entry shall be at the bottom of panels. A substantial gland plate or plates shall be provided for effecting the termination of cables if a panel is situated in a humid, dusty and aggressive environment. The gland plates shall be arranged so that the cables entering can rise vertically inside the panel without bending.

The arrangement of the cable glands shall be such that access to the glands for tightening shall be provided.

In case of entry of single core power conductor a non magnetic gland plate must be provided.

### **9.7.1 CABLE GLANDS**

All cable glands fitted in panels shall be "screw-type" cable glands with a screwed on cap-nut and a hermetic sealing ring. The degree of protection of cable glands shall be at least IP68.

Counter nuts, where needed for secure fastening of cable glands, shall be suitable for the cable gland.

Special EMC cable glands shall be installed where EMC-screened cables enter panels. EMC counter nuts with cutting edges shall be used wherever EMC cable glands are used in lacquered, anodized and/or powder coated panel housings – see section 6.6 *EMC Requirements*.

Where flexible cables lead in or out of panels, cable glands with bending protection shall be installed.

## 10 EQUIPMENT AND WIRING IN PANELS

### 10.1 CIRCUIT BREAKER AND SWITCH CLASSIFICATION

In this Standard Technical Specification circuit breakers and switches are categorized as follows:

- Air Circuit Breaker – ACB
- Molded Case Circuit Breaker – MCCB
- Miniature Circuit Breaker – MCB
- Motor Protection Circuit Breaker – MPCB
- Combination Fuse Switch – CFS
- Load Switch Disconnecter – LSD

#### 10.1.1 ACB – AIR CIRCUIT BREAKER

An ACB is specified in this Standard Technical Specification as a low-voltage circuit breaker intended for use in the current range of 1600 – 6300 A. The fault current capacity of ACBs shall be  $\geq 50$  kA (400 VAC). ACBs overcurrent device shall be adjustable so that selectivity in the LV distribution is achieved. The characteristic curve of the ACB shall at least consist of LSI.

#### 10.1.2 MCCB – MOULDED CASE CIRCUIT BREAKER

MCCBs are used in the current range of 40 – 1250 A. The fault current capacity of MCCBs shall be minimum 35 kA (400 V AC) or higher if the short circuit current is greater. MCCBs overcurrent device shall be adjustable so that selectivity in the LV distribution is achieved. The characteristic curve of the MCCB shall at least consist of LS/I.

#### 10.1.3 MCB – MINIATURE CIRCUIT BREAKER

MCBs are used in the current range of  $\leq 50$  A and are intended for use in installations with low fault current capacity (under 25 kA, 400 V AC) unless protected by upstream fuses.

The fault current capacity shall be  $\geq 15$  kA according to ÍST EN 60947-2 *Low-voltage switchgear and control gear - Part 2: Circuit-breakers*. These in turn must be protected by overcurrent protection with a fault current capacity  $\geq 35$  kA.

MCBs shall have both overcurrent and short-circuit protection. MCBs shall generally be of B-type for lighting and C-type for other loads.

#### 10.1.4 MPCB – MOTOR PROTECTION CIRCUIT BREAKER

The Motor Protection Circuit Breakers (MPCBs) provide short circuit protection, overload protection and motor disconnect functions. Generally the operational range of MPCBs is limited to 32 A. The installation of MPCB equipment is subject to the approval of the Owner.

#### 10.1.5 CFS – COMBINATION FUSE SWITCH

Combination Fuse Switches may, or have to be used in specific cases. The installation of CFS equipment is subject to the approval of the Owner.

#### 10.1.6 LSD – LOAD SWITCH DISCONNECTOR

LSDs may be used to sectionalize between two or more incoming circuit breakers. In some cases LSDs may be used as incoming switch in DBs rated  $\leq 100$  A.

The installation of LSDs is subject to the approval of the Owner.

### **10.1.7 ON-LOAD FUSE SWITCH**

The use of an on-load fuse switch shall be subject to the approval of the Owner. The switches shall have a fuse alarm indicator.

### **10.1.8 LOAD BREAK SWITCHES**

Load break switches shall generally be three-pole, with a breaking capacity according to ÍST EN 60947-3.

### **10.1.9 VARIABLE SPEED DRIVES AND SOFT STARTERS**

The preferred type of a Variable Speed Drive VSD is the PWM (Pulse Width Modulation) type controllers. This will however not exclude the use of other drive technologies.

The VSD and soft starter shall generally be fed from MCCB's with short circuit protection.

The design of VSD and soft starters shall insure sufficient ventilation/cooling for the equipment through filters if situated in dirty environment provide good accessibility for control and maintenance, possibly install the drives control unit in the front of the panel door.

## **10.2 CONTROL CIRCUIT DEVICES**

Control circuit devices for panel and control box mounting are among others pushbutton actuators, indicator lights and selector switches.

All control circuit devices shall maintain the panels IP-code. If control circuit devices are added to a current panel they shall be of the same or similar type of those installed.

LEDs shall be used for illumination of buttons and indicating lights. Other light sources are not accepted.

The colors of all LEDs and indications shall comply with the standard ÍST EN 60073 *Basic and safety principles for man-machine interfaces, marking and identification - Coding principles for indication devices and actuators* and must be approved by the Owner prior to installation.

## **10.3 PANEL INSTRUMENTS**

Instruments and control equipment may be mounted on the doors or the fixed portions of the panels. Care must be taken to ensure that the equipment is supported sufficiently and secured against shock or vibration.

Where specified, indicating instruments are to be of the flush mounting type with square dial, a minimum of 75 mm across. The instruments shall be of the 90° dial type with black graduations and numerals on a white background.

Voltmeters are to be protected by means of MCBs.

The ampere- and voltmeters shall be able to handle 20% continuous overload.

## **10.4 CIRCUIT BREAKERS**

### **10.4.1 GENERAL**

The circuit breaker operating mechanisms should be of the "Trip Free" type. The performance characteristics of the circuit breakers under normal and abnormal conditions shall be as stated in the requirements of Class P2 of ÍST EN 60947-2 *Low-voltage switchgear and controlgear - Part 2: Circuit-breakers*. The short time current duration shall be 1 second.

Three pole circuit breakers shall be provided on the incoming, interconnections or bus section circuits so that the neutral will not be switched. Circuit breakers are to be provided with a mechanical "on/off" indicator visible from the front of the board.

Where circuit breakers are specified to be of the withdrawable hand or electrically operated type they shall be provided with interlocks such that:

- Withdrawal of breaker will initiate tripping well before the plugging contacts separate.
- Access to the breaker cannot be obtained unless it is completely withdrawn.
- Closing of the breaker cannot be affected unless it is in the fully plugged in position or in test position.

The withdrawing mechanism should be screw or lever operated from the front of the panel and should be so designed that only moderate effort is required to ensure satisfactory operation. The circuit breaker carriage should be provided with pins or guide rails for aligning the plugs and sockets before entry is affected.

Short circuit interrupters must be capable of instantaneous disconnection of a three-phase fault of minimum 36 kA.

All MCCBs shall have a switch handle come through the front cover/door of their panel compartment when placed in separate compartments. The switch handle's position shall be in line with the single-line diagram on the outside of the front cover/door, see 9.1.6.3 – *Circuit breaker compartment*, when the MCCB is in the “closed” position.

Selection of circuit breaker types shall conform to table 10.1, see also section 10.1 – *Circuit breaker and switch classification*.

Table 10.1. Circuit breaker type and rating.

Circuit breaker type	Circuit breaker rating			
	$I_r \leq 32 \text{ A}$	$I_r \leq 50 \text{ A}$	$40 \text{ A} \leq I_r \leq 1250 \text{ A}$	$I_r \geq 1600 \text{ A}$
	MPCB	MCB	MCCB	ACB

Circuit breakers and switches should generally not be subjected to more than 70% continuous load of their nominal rating. All circuit breakers excluding ACB's should therefore be rated to carry 30% more than their continuous calculated load.

#### 10.4.2 INCOMING PANEL FEEDER

Panels of nominal load above 16 A shall be equipped with a main load switch disconnecter allowing manual disconnection of the panel.

The selection of the load switch disconnecter shall be in accordance with section 10.1 *Circuit breaker and switch classification* and table 10.1. The design of a different configuration shall be subject to the Owners approval.

#### 10.4.3 RESIDUAL CURRENT PROTECTIVE DEVICES

Residual current protective devices (RCD) shall be four-pole, with rated current 63 A and rated residual fault current 30 mA if not otherwise specified. RCD's shall only be applied in specific cases and situations and is subject to the approval of the Owner.

#### 10.4.4 LOCK OUT-TAG OUT

All Lockable Safety Isolation Switches shall have the necessary equipment for locking the switches in the “open” (off) position.

All matters in relation to installation, process and requirements for the Lockable Safety Isolation Switches shall be according to the NA-06-STS002 Specification For LOTOV of Electrical Equipment.

## 10.5 MOTOR STARTING

Starting of motors shall generally be direct on line starting. Speed control starting or soft starting is to be used in special cases. Starting methods of all motors are subject to the approval of the Owner.

All motor circuitry shall be equipped with approved motor protection for each application.

**NOTE**, in the context to motors and motor starting the requirements in the standard NA-06-ST002 Specification For LOTOV of Electrical Equipment shall also be fulfilled.

## 10.6 CONTACTORS AND RELAYS

The control voltage of all contactors and relays shall be according to section 4.1.2 *Voltage levels*. In general for LV control voltage installation the voltage shall be 230 V AC or 24 V DC, 400 V control voltage installation is not accepted.

All power contactors shall generally be selected according to the AC-4 utilization category. Deviation in selection of utilization category is subject to the approval of the Owner. The contactors shall be equipped with at least 1 NO + 1 NC auxiliary contacts. The selection of power contactors shall always conform to the directions set forth by the manufacturer of the contactors.

All control relays shall be of the base type relay. All control relays, both AC and DC relays, shall have a relay status indicating LED. DC control relays shall also have a relay coil suppression diode.

Unless otherwise specified control relays will be mounted inside panels and shall be grouped to indicate clearly the associated control system. All relays shall be closed with transparent covers that shall be suitably retained. Relay contacts must be adequately rated for the required duty and be suitable for prolonged operations.

## 10.7 CURRENT TRANSFORMERS

Current transformers (CT) shall be selected specially for each application considering the use for measuring or protection purpose.

The burden of the CT shall be selected so that the CT is loaded with at least 40% of its rated burden.

The wiring of the current loop shall be such that not more than 10% of the CTs burden is consumed by the wiring.

Current on the secondary shall generally be 1 A.

All CTs must be individually grounded with minimum 2.5 mm<sup>2</sup> green/yellow wire not longer than 2 m.

All current transformers are to be supplied with firmly attached labels containing the following information: Ratio, burden, overcurrent factor and rated time duration, class of accuracy and the standards complied with (i.e. ÍST EN 60044-1,-2 -5 *Instrument transformers* for protective transformers).

## 10.8 WIRE TERMINALS

All connection between external cabling and internal panel wires shall be through modular terminal blocks. Terminal blocks shall accommodate at least 4 mm<sup>2</sup> wire and be a part of a broad production range including fasteners, separating- and endplate etc. Terminal blocks shall be suitable for fastening on DIN-rails. If space is restricted, terminal blocks in 2 or 3 layers can be used.

## 10.9 WIRING

The panels are to be complete with all necessary control wiring that is to be of type flexible H07V-K or equivalent. The control wiring is to be complete with numbered ferrules



corresponding to wire reference numbers on all related drawings and is to be fitted with pressed end sleeve lugs if productive. The wiring is to be carried out in a workmanlike manner and provided with adequate clamps, cleats and similar. Wires, with a cross section  $\leq 6 \text{ mm}^2$ , shall be laid in closed wire ducts made of plastic designed with ample space (30%) for future additions. Where inter panel wiring is necessary, suitable bushes of rubber, brass, Bakelite, or similar material, must be fitted to holes in the steelwork through which the wiring passes.

Note: Where multi strand cable conductor (double insulated conductor) is installed between the subsidiary busbars, isolators and circuit breakers, care is to be taken that the cable conductor is laid in a short circuit proof manner. The cross section terminals and accessories are rated to withstand the mechanical forces generated under fault conditions and that the final layout fulfills the requirement in section 434.3 of ÍST 200 *Electrical installations of buildings*. Soldered lugs must not be used to connect these conductors.

Panel control wires shall have the following color code.

110 V DC system:	Black (+), Grey
48 V DC system:	Red (+), Grey
24 V DC system:	Brown (+), Grey
230 V from main incoming system:	Brown or Black (L), Light Blue (N), Green/Yellow (PE). <i>NOTE, where the 230 V AC and 24 V DC are used as control voltages in the same panel the 230 V AC wires shall be in black color.</i>
230 V derived locally by a transformer:	Red (L), Blue (N), Green/Yellow (PE).
Analog wires:	Violet, Green/Yellow (PE).
Outgoing wires supplied from outside and terminated on terminals like Volt free contacts, Control, Alarms:	Orange

The minimum cross sectional area of wires shall generally be  $1,5 \text{ mm}^2$  for 230 V wiring and  $1,0 \text{ mm}^2$  for DC and analog wires. Exceptions from this rule are where equipment requires wires with less cross sectional area. The use of those wires is subject to the approval by the Owner.

## 10.10 WIRE MARKING

To ensure traceability of a wire within MCC and control panels all wires shall be marked on drawings. The wires in panels and in junction boxes shall be neatly and clearly marked as indicated on the schematic and wiring diagrams on drawings. The wiring marking tags shall be made from a plastic durable type with printed durable marking. Wiring marking with a pen are not accepted.

All wires within the panels shall be marked in both ends of the wire. The numbering structure on drawings shall be the sheet drawing number and then a serial number.

Example: A wire number **401.1**

**401** the sheet number; **1** the serial number i.e. the first wire on the drawing sheet.

All wiring marking material, schematic and wiring diagrams on drawings is subject to approval by the Owner.

## 10.11 MARKING AND LABELING OF EQUIPMENT

Nameplates shall be provided for identification of all panel-mounted devices, dials, gauges, instruments and control devices.

All circuit breakers and switches shall be equipped with an engraved label – see section 9.1.8 *Panel and equipment labeling* or other permanent type markings which show the breaker/switch positions.

Removable items of equipment shall be labeled on the removable part and on the relevant fixed part.

All electrical equipment, terminals and etc. must be clearly marked according to the electrical schematic diagram.

A data pocket shall be provided on the inside of all panel doors for electrical drawings.

There shall be a legible “Branch Lists” (IS: töflugreinaskrá) on prescribed sheets showing all branches, their ratings and the points they supply, according to drawings. This list shall be plastic coated and securely fastened inside the panel door. The Owner will provide the “Branch List” form.

## **11 LIGHTING**

### **11.1 GENERAL**

All lighting equipment in the production area shall be suitable for installation in an aggressive industrial environment.

Lighting in office, service and personnel buildings shall comply with *ÍST 200 Electrical installation of buildings* and other relevant standards.

The lighting equipment shall be a standard product, of high quality, energy efficient and manufactured for the purpose it is intended.

All luminaries, control gear, lamps, and lighting components shall be suitable for 1ph, 230V, 50 Hz.

### **11.2 DESIGN REQUIREMENTS**

Lighting fixtures for the production area shall be of industrial type, suitable for an environment in which alumina and carbon dust and vapors containing fluorides are present.

In general high-bay fixtures ( $\geq 5$  m) shall be fitted with anodized aluminum reflector in a die-cast aluminum body and HPS (High Pressure Sodium) lamps.

Outside floodlights shall have visors and streetlights shall be of sharp cut-off type, minimizing light spillage. The placement of floodlights and streetlights shall be calculated in a light calculation program. The design shall take into consideration the existent lighting and environmental issues (lighting pollution).

Emergency and exit lighting shall comply to *ÍST EN 50172 Emergency escape lighting systems* and *ÍST EN 1838 Lighting application - Emergency lighting*. In the production areas additional emergency lighting is needed and shall be designed in cooperation with NA production personnel.

All lighting design and selection of lighting fixtures is subject to the Owners approval.

### **11.3 PRODUCTS**

Lighting fixtures shall be supplied with all accessories necessary for the type of mounting specified.

Ballast in lamps shall be of electronic type.

#### **11.3.1 INDOOR LIGHTS**

In general indoor lighting in production areas is high bay fixtures fitted with HPS lamps 250 W or 400 W. Other fixtures are fluorescent lamps. The lighting fixture shall be at least IP65.



### **11.3.2 EMERGENCY AND EXIT LIGHTS**

Emergency and exit lights with integral battery backup shall be of self-testing type. Industrial type emergency lights shall be of rugged construction with twin PAR36 lamps or comparable. All lighting design and selection of emergency and exit lights is subject to the Owners approval.

### **11.3.3 OUTDOOR LIGHTING**

In general 250 W and 70 W HPS lamps are used in outdoor lighting. The lighting fixture shall be at least IP54.

### **11.3.4 LIGHT POLES**

#### **11.3.4.1 Street Light Poles**

Street Light Pole shall be heavy duty, tapered, hot dipped galvanized steel, with base plate for anchor mounting, generally 10 m in height.

It shall have provision for terminating 5x10 mm<sup>2</sup> Cu cable. The light pole shall be fitted with a fused connector box within the pole according to ÍST EN 61439 *Low-voltage switchgear and controlgear assemblies*. The light pole shall have a ground connection point accessible through the light pole termination opening.

Street Lighting Pole shall be made for Tenon-Slip fit mounted fixture or Tenon-bracket with two Light fixtures.

#### **11.3.4.2 Stanchion Light Poles**

Stanchion light poles shall be of 2.5 m nominal height, round tubular, hot dipped galvanized steel poles, or other Owner approved material, of 75 mm diameter minimum. The stanchion pole shall have a welded base plate for either anchor mounting or bolting to steel.

The pole should have a provision to lower the light fitting to below 1.8 m employing either telescopic action or hinge action.

## **12 ACCESSORIES**

### **12.1 GENERAL**

#### **12.1.1 MOUNTING HEIGHTS**

Generally the mounting of switches, sockets and socket combination boxes shall be 1500 mm from floor surface.

### **12.2 JUNCTION BOXES**

Junction boxes shall be of ample size for the intended components or equipment. In production areas and outdoors the IP-rating of junction boxes shall be IP65 or higher. When placed in extreme heat (near hot or molten metal) the junction boxes shall be made of material that can withstand the heat without deformation. All unused glands shall be closed by means of a lid of an appropriate type, intended for this purpose.

### **12.3 SOCKET OUTLETS**

In general in production area outside the Earth Free Zone, socket combination boxes are used. A 30 mA residual current device (RCD) shall be installed if appropriate according to ÍST 200 *Electrical installation of buildings*. In production areas the IP-rating of socket outlets shall be IP44 or higher. The configuration of the boxes is subject to the Owners approval.

All socket outlets will be grounded by a separate green/yellow ground wire, except in the Earth Free Zones – see section 5.1.1 *Earth Free Zone*.

## **12.4 LIGHT SWITCHES**

### **12.4.1 GENERAL**

All switches in production areas shall be of the surface mounting type IP44.

### **12.4.2 PHOTOELECTRIC SWITCHES**

Photoelectric switches are generally not used at NA. If used, the switches shall be complete with mounting accessories. The photoelectric switches housing shall be of protection class IP44 or higher.

### **12.4.3 ASTRONOMICAL CLOCK**

The astronomical clock shall have a longitude and latitude parameters where geographical location can be programmed which allows automatic commutation of controlled circuit according to sunrise and sunset.

The astronomical clock shall allow for multiple switching within every 24 hours and have an offset timing feature. It shall be possible to switch the output of the astronomical clock manually on and off.

The astronomical clock's auxiliary power supply shall be 230 V AC, 50 Hz with a minimum 1x 16 A AC-1 contact.

## **12.5 HEATING EQUIPMENT**

### **12.5.1 PANEL HEATERS**

The electrical panel heaters shall be of a standard production. The heating panel shall include, control equipment, thermal overload protection and all necessary installation material. Electric heaters shall be wall mounted for 230 V AC supply with a protection class IP44 or higher.

The surface heat shall not exceed 90 °C at full load.

### **12.5.2 ELECTRICAL HEATING FANS**

Electric heating fans shall be of a standard production either wall or ceiling mounted for 400/230 V AC. The heaters shall be with a thermostat at the air inlet, adjustable 5-35 °C. Noise level shall not exceed 47 dB in 1 m distance. Protection class shall be IP44 or higher.

## **12.6 NETWORK / DATA OUTLETS**

The minimum requirements for cable types – see section 8.6 *Ethernet twisted pair cables*.

## **12.7 FIRE DETECTION AND PROTECTION**

Fire alarm system shall be provided in all buildings and shall be compatible with existing Fire alarm system.

The minimum requirements for cable types – see section 0 *Fire detection and alarm cables*.